

Design

The cast steel gate valves are designed and manufactured to provide maximum service life and dependability. All gate valves are full ported and meet the design requirements of American Petroleum Institute standard API600&API 6D, British standard BS1414& BS EN 1984 and generally, conform to American Society of Mechanical Engineers standard ASME B16.34. Valves are available in a complete range of body/bonnet materials and trims.

Ranges of materials

Standard body/bonnet materials include nine grades of carbon, low alloy and stainless steels. For special applications they can be supplied in other grades of alloy and stainless steel. There's a full range of trim materials to match any service. optional packing and gasket materials are available for a full range of service conditions.

Available Modifications

Trim Changes
End Connection Modifications
Packing and Gasket Change
Operator Mounting
Handwheel Extensions

Pressure Equalizing
By-Pass
Customer Specified Coatings
Weld End Bore Changes
Oxygen & Chlorine Clearing & Packaging

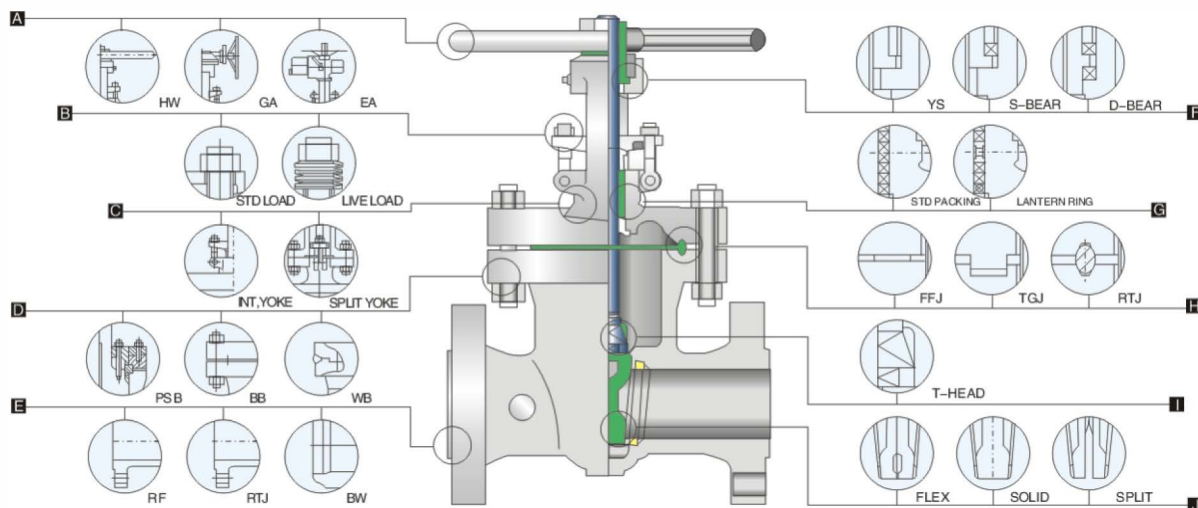

A Operation

Large handwheels for easy operation. also available with gearing, motor actuators, pneumatic or hydraulic actuators for more difficult services.

B Live Load Packing

In services requiring frequent cycling or with high pressure/temperature variations, live loading extends the service life between maintenance periods by requiring less adjustments. Belleville springs are employed to provide constant packing gland stress.

C OS&Y

Outside screw and yoke. Cast steel gate valve yoke integral with bonnet for 150Lb-8", 600Lb-6", 900Lb-4" & small.

D BB

bolted bonnet, welding bonnet and pressure seal bonnet in services requiring frequent cycling or with high pressure/temperature variations.

E End Connections

A choice of flanged, RTJ flanged or buttwelding end for piping flexibility.

F Yokesleeve

Extra long thread engagement between yoke sleeve and stem provide long thread life. valves of sizes larger than 150Lb-12", 300Lb-10", 600Lb-6", 900Lb/1500Lb/2500Lb-4" are regularly provided with roll bearing yokes.

G Lantern Ring And Double Packing Set

lantern ring leak-off fitting connection and double packing stack is optionally available for critical services.

H Body-to-Bonnet Joint

A flat face gasket joint is used in the 150lb valves. A male and female joint is used in 300lb to 600lb valves. ring joint is used in the body to bonnet connections in 900lb & higher rated valves.

I Stem

All wedge gate valves are provided with upset forged T-head stems. By forging the T-head, the stem at the stem-wedge connection is strengthened, this design also allows the wedge possibility of a bent stem jamming the wedge.

J Wedge

Integral guide rib faces assure self-centering of wedge. flexible wedge gate valve has a one-piece, twin-disc wedge, which is designed so that each half flexes independently, available in solid, flex split and his designs.

Applicable standards:

- STEEL GATE VALVES API 600/API 6D
- STEEL GATE VALVES ISO 10434/ISO 14313
- STEEL VALVES, ASME B16.34
- FACE TO FACE, ASME B16.10
- END FLANGES, ASME B16.5
- BUTTWELDING ENDS, ASME B16.25
- INSPECTION AND TEST API 598/API 6D

Design descriptions:

- FULL PORT DESIGN
- OS&Y OUTSIDE SRCEW AND YOKE
- BB.BOLTED BONNET
- FLEXIBLE WEDGE, FULLY GUIDED
- CHOICE OF SOLID OR SPLIT WEDGE
- RENEWABLE SEAT RINGS
- FORGED T-HEAD STEM
- RISING STEM AND NON-RISING HANDWHEEL
- FLANGED OR BUTTWELDING ENDS
- AVAILABLE WITH BG OPERATOR

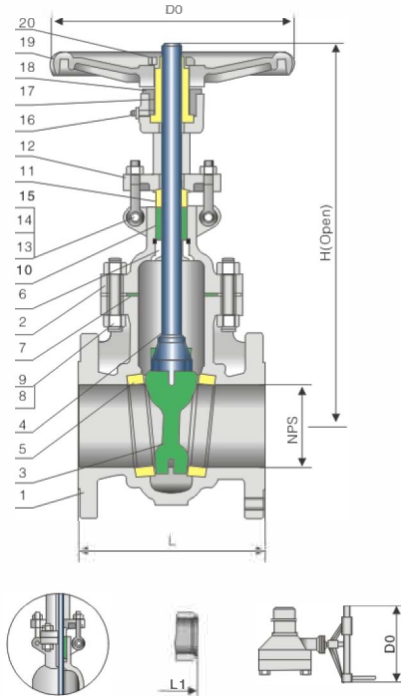

Materials of parts

No	Part Name	Carbon steel	ASTM Material 1 ¹ / ₄ cr- ¹ / ₂ mo	Carbon Steel
1	Body	A216-WCB	A217-WC6	A352-LCB
2	Bonnet	A216-WCB	A217-WC6	A352-LCB
3	Wedge	A216-WCB+CR13	A217-WC6+HF	A352-LCB+CR13
4	Stem	A182-F6a	CR-MO-V	A182-F6a
5	Seat ring	A105+CR13	A182-F11+HF	A350-LF2+CR13
6	Stem Backseat	A276-420	A276-304	A276-420
7	Bonnet Gasket	Spiral wound(Graphite+304)		
8	Bonnet Stud	A193-B7	A193-B16	A320-L7
9	Bonnet Stud Nut	A194-2H	A194-7	A194-4
10	Packing	Graphite		
11	Gland	A276-420	A276-304	A276-420
12	Gland Flange	A216-WCB	A217-WC6	A352-LCB
13	EyeBolt Pin	Carbon steel	A276-420	Carbon steel
14	Eyebolt	Carbon steel	A193-B7	Carbon steel
15	Eyebolt Nut	Carbon steel	A194-2H	Carbon steel
16	Grease Fitting	Brass+Steel		
17	Yoke Sleeve	Aluminum-Bronze		
18	Yokesleeve Jam nut	Carbon Steel		
19	Handwheel	Malleable Iron		
20	Handwheel Nut	Carbon Steel		

Note: 1) ductile ni-resist optional
2) wedge and seat ring may either be solid facing material or a base material equal to or better than the body/bonnet material with facing as shown.

Dimensional datas of ANSI Class 150Lb

NPS DN	2	2 1/2	3	4	6	8	10	12	14	16	18	20	24	26	28	30	32	36	in
	50	65	80	100	150	200	250	300	350	400	450	500	600	650	700	750	800	900	mm
L (RF)	7.00	7.50	8.00	9.00	10.50	11.50	13.00	14.00	15.00	16.00	17.00	18.00	20.00	22.00	24.00	24.00	28.00	28.00	in
	178	191	203	229	267	292	330	356	381	406	432	457	508	559	610	610	711	711	mm
L1 (BW)	85	9.50	11.12	12.00	15.88	16.50	18.00	19.75	22.50	24.00	26.00	28.00	32.00	34.00	36.00	36.00	38.00	40.00	in
	216	241	283	305	403	419	457	502	572	610	660	711	813	864	914	914	965	1016	mm
H (open)	15.25	17.00	18.88	23.00	30.50	37.62	45.50	53.12	59.38	67.00	74.50	83.50	98.25	110.50	116.50	124.00	129.00	146.50	in
	386	434	480	584	765	956	1149	1350	1508	1703	1892	2119	2500	2806	2960	3150	3280	3720	mm
Do	8	8	10	12	12	14	16	15	20	22	24	26	29	29	32	32	38	40	in
	200	200	250	300	300	350	400	450	500	550	600	640	700	720	800	800	950	1000	mm
wt(kg)	18	25	32	50	77	121	178	265	463	463	621	792	1521	1521	1838	2261	2490	3310	RF
	15	18	26	41	69	108	156	248	424	424	587	752	1570	1570	1900	3310	2540	3380	BW

Dimensional datas of ANSI Class 300Lb

NPS DN	2	2 1/2	3	4	6	8	10	12	14	16	18	20	24	26	28	30	32	36	in
	50	65	80	100	150	200	250	300	350	400	450	500	600	650	700	750	800	900	mm
L1 (RF/BW)	8.50	9.50	11.12	12.00	15.88	16.50	18.00	19.75	30.00	33.00	36.00	39.00	45.00	49.00	53.00	55.00	60.00	68.00	in
	216	241	283	305	403	419	457	502	762	838	914	991	1143	1245	1346	1397	1524	1727	mm
L2 (RTJ)	9.12	10.12	11.75	12.62	16.50	17.12	18.62	20.38	30.62	33.62	36.62	39.75	45.88	50.00	54.00	56.00	61.12	69.12	in
	232	257	298	321	419	435	473	518	778	854	930	1010	1165	1270	1372	1422	1553	1756	mm
H (open)	16.12	17.88	20.00	24.00	31.75	39.38	47.62	55.75	62.25	67.88	77.12	86.38	102.00	117.00	122.00	126.00	130.00	152.00	in
	410	453	509	612	805	1000	1210	1415	1580	1725	1960	2195	2590	2975	3100	3200	3300	3860	mm
Do	8	8	10	12	14	16	18	20	22	22	24	26	29	29	32	32	38	40	in
	200	200	250	300	350	400	450	500	550	550	600	640	720	720	800	800	950	1000	mm
wt(kg)	23	35	50	71	144	209	322	482	683	950	1145	1635	2660	3090	3310	3595	3720	3985	RF
	17	26	39	53	113	164	256	390	565	805	965	1410	2305	2540	2725	3055	3360	3630	BW

Applicable Standards:

- STEEL GATE VALVES API 600/API6D
- STEEL GATE VALVES ISO 10434/ISO 14313
- STEEL VALVES, ASME B16.34
- FACE TO FACE, ASME B16.10
- END FLANGES, ASME B16.5
- BUTTWELDING ENDS, ASME B16.25
- INSPECTION AND TEST API 598/API 6D

Design descriptions:

- FULL PORT DESIGN
- OS&Y OUTSIDE SCREW AND YOKE
- BB.BOLTED BONNET
- FLEXIBLE WEDGE, FULLY GUIDED
- CHOICE OF SOLID OR SPLIT WEDGE
- RENEWABLE SEAT RINGS
- FORGED T-HEAD STEM
- RISING STEM AND NON-RISING HANDWHEEL
- FLANGED OR BUTTWELDING ENDS
- AVAILABLE WITH BG OPERATOR

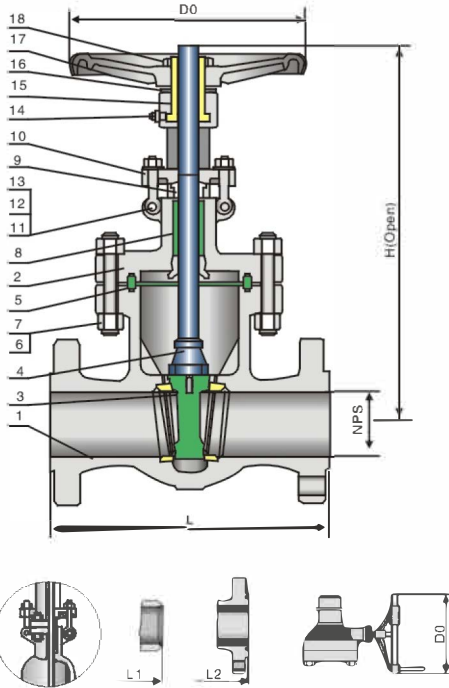

Materials of parts

No	Part Name	Carbon Steel	ASTM Material 1 ¹ / ₄ Cr-1 ¹ / ₂ Mo	Carbon Steel
1	Body	A216-WCB	A217-WC6	A352-LCB
2	Bonnet	A216-WCB	A217-WC6	A352-LCB
3	Wedge	A216-WCB+CR13	A217-WC6+HF	A352-LCB+CR13
4	Stem	A182-F6a	CR-MO-V	A182-F6a
5	Seat Ring	A105+CR13	A182-F11+HF	A350-LF2+CR13
6	Stem Backseat	A276-420	A276-304	A276-420
7	Bonnet Gasket	Spiral Wound(Graphite+304)		
8	Bonnet Stud	A193-B7	A193-B16	A320-L7
9	Bonnet Stud Nut	A194-2H	A194-7	A194-4
10	Packing	Graphite		
11	Gland	A276-420	A276-304	A276-420
12	Gland Flange	A216-WCB	A217-WC6	A352-LCB
13	Eyebolt Pin	Carbon steel	A276-420	Carbon steel
14	Eyebolt	Carbon steel	A193-B7	Carbon steel
15	Eyebolt Nut	Carbon steel	A194-2H	Carbon steel
16	Grease Fitting	Brass+steel		
17	Yokesleeve	Aluminum-bronze		
18	Yokesleeve Jam Nut	Carbon Steel		
19	Handwheel	Malleable Iron		
20	Handwheel Nut	Carbon Steel		

Note: 1) Ductile Ni-resist optional
2) Wedge and seat ring may either be solid facing material or a base material equal to or better than the body/bonnet material with facing as shown.

Dimensional datas of ANSI Class 600Lb

NPS DN	2 50	2 1/2 65	3 80	4 100	6 150	8 200	10 250	12 300	14 350	16 400	18 450	20 500	24 600	26 650	28 700	30 750	32 800	36 900	in mm
L/L1 (RF/BW)	11.50 292	13.00 330	14.00 356	17.00 432	22.00 559	26.00 660	31.00 787	33.00 838	35.00 889	39.00 991	43.00 1092	47.00 1194	55.00 1397	57.00 1448	61.00 1549	65.00 1651	70.00 1778	82.00 2083	in mm
L2 (RTJ)	11.62 295	13.12 333	14.12 359	17.12 435	22.12 562	26.12 664	31.12 791	33.12 841	35.12 892	39.12 994	43.12 1095	47.25 1200	55.38 1407	57.50 1461	61.50 1562	65.50 1664	70.62 1794	82.62 2099	in mm
H (open)	16.50 418	18.75 476	20.38 518	25.50 646	33.00 840	40.38 1025	48.38 1230	57.00 1450	62.00 1575	70.62 1795	76.00 1930	87.00 2210	101.50 2580	105.00 2665	109.50 2780	114.00 2895	124.00 3150	140.00 3560	in mm
Do	8 200	10 250	10 250	12 300	18 450	20 500	24 600	24 600	24 600	24 600	26 640	26 640	29 720	29 720	32 800	32 800	38 950	40 1000	in mm
wt(kg)	36 29	52 42	67 53	112 83	170 125	393 310	610 472	890 730	1245 1055	1530 1240	1965 1625	2450 2030	2995 2590	3475 2855	3725 3065	4045 3440	4185 3780	4480 4085	RF BW

Dimensional datas of ANSI Class 900Lb

NPS DN	2 50	2 1/2 65	3 80	4 100	6 150	8 200	10 250	12 300	14 350	16 400	18 450	20 500	24 600	in mm
L/L1 (RF/BW)	14.50 368	16.50 419	15.00 381	18.00 457	24.00 610	29.00 737	33.00 838	38.00 965	40.50 1029	44.50 1130	48.00 1219	52.00 1321	61.00 1549	in mm
L2 (RTJ)	14.62 371	16.62 422	15.12 384	18.12 460	24.12 613	29.12 740	33.12 841	38.12 968	40.88 1038	44.88 1140	48.50 1232	52.50 1334	61.75 1568	in mm
H (open)	19.62 498	21.50 547	22.50 573	26.62 678	35.50 900	45.00 1103	53.00 1345	60.00 1525	74.88 1900	81.00 2055	87.00 2215	101.00 2565	104.00 2640	in mm
Do	10 250	10 250	12 300	18 450	20 500	24 600	26 640	29 720	32 800	32 800	38 950	38 950	40 1000	in mm
wt(kg)	74 54	131 105	101 78	172 135	335 260	640 515	1100 920	1600 1380	2250 2010	2850 2565	3060 3485	3935 3250	49.00 4065	RF BW

Applicable Standards:

- STEEL GATE VALVES API 600/API6D
- STEEL GATE VALVES ISO 10434/ISO 14313
- STEEL VALVES, ASME B16.34
- FACE TO FACE, ASME B16.10
- END FLANGES, ASME B16.5
- BUTTWELDING ENDS, ASME B16.25
- INSPECTION AND TEST API 598/API 6D

Design descriptions:

- FULL PORT DESIGN
- OS&Y OUTSIDE SRCEW AND YOKE
- BB. BOLTED BONNET
- FLEXIBLE WEDGE, FULLY GUIDED
- CHOICE OF SOLID OR SPLIT WEDGE
- RENEWABLE SEAT RINGS
- FORGED T-HEAD STEM
- RISING STEM AND NON-RISING HANDWHEEL
- FLANGED OR BUTTWELDING ENDS
- AVAILABLE WITH BG OPERATOR

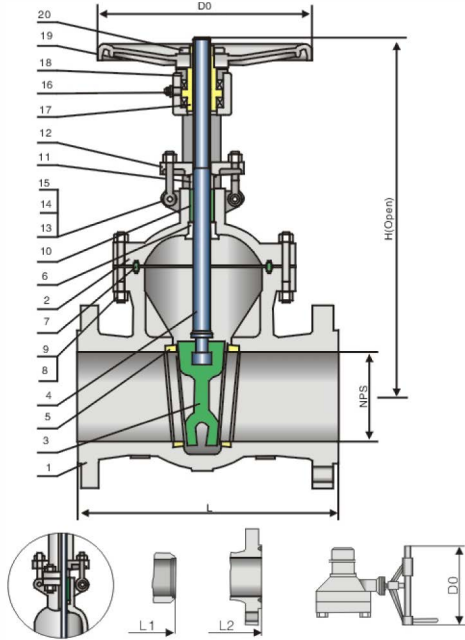

Materials of parts

No	Part Name	Carbon Steel	ASTM Material 1 ¹ / ₄ Cr-1 ¹ / ₂ Mo	Carbon Steel
1	Body	A216-WCB	A217-WC6	A352-LCB
2	Bonnet	A216-WCB	A217-WC6	A352-LCB
3	Wedge	A216-WCB+CR13	A217-WC6+HF	A352-LCB+CR13
4	Stem	A182-F6a	CR-MO-V	A182-F6a
5	Seat Ring	A105+CR13	A182-F11+HF	A350-LF2+CR13
6	Stem Backseat	A276-420	A276-304	A276-420
7	Bonnet Gasket	Spiral Wound(Graphite+304)		
8	Bonnet Stud	A193-B7	A193-B16	A320-L7
9	Bonnet Stud Nut	A194-2H	A194-7	A194-4
10	Packing	Graphite		
11	Gland	A276-420	A276-304	A276-420
12	Gland Flange	A216-WCB	A217-WC6	A352-LCB
13	Eyebolt Pin	Carbon steel	A276-420	Carbon steel
14	Eyebolt	Carbon steel	A193-B7	Carbon steel
15	Eyebolt Nut	Carbon steel	A194-2H	Carbon steel
16	Grease Fitting	Brass+steel		
17	Yokesleeve	Aluminum-bronze		
18	Yokesleeve Jam Nut	Carbon Steel		
19	Handwheel	Malleable Iron		
20	Handwheel Nut	Carbon Steel		

Note: 1) Ductile Ni-resist optional
 2) Wedge and seat ring may either be solid facing material or a base material equal to or better than the body/bonnet material with facing as shown.

Dimensional datas of ANSI Class 1500Lb

NPS DN	2 50	2 ¹ / ₂ 65	3 80	4 100	6 150	8 200	10 250	12 300	14 350	16 400	18 450	20 500	24 600	in mm
L1.1 (RF/BW)	14.50 368	16.50 419	18.50 470	21.50 546	27.75 705	32.75 832	39.00 991	44.50 1130	49.50 1257	54.50 1384	60.50 1537	65.50 1664	76.50 1943	in mm
L2 (RTJ)	15.50 371	16.62 422	18.62 473	21.62 549	28.00 711	33.12 841	39.38 1000	45.12 1146	50.25 1276	55.38 1407	61.38 1559	66.38 1686	77.62 1972	in mm
H (open)	24.25 615	26.00 658	30.00 760	34.12 868	39.50 1005	45.00 1145	54.00 1370	61.00 1550	74.88 1900	80.50 2050	93.75 2380	101.50 2580	114.75 2915	in mm
Do	10 250	12 300	18 450	20 500	24 600	18 460	18 460	24 600	24 600	24 600	24 600	24 600	24 600	in mm
wt(kg)	116 105	166 150	209 188	296 265	510 412	920 760	1910 1640	3145 2755	4100 3200	6200 5300	8965 8070	13100 11790	15860 14275	RF BW

Dimensional datas of ANSI Class 2500Lb

NPS DN	2 50	2 ¹ / ₂ 65	3 80	4 100	6 150	8 200	10 250	12 300	14 350	16 400	18 450	20 500	24 600	in mm
L1.1 (RF/BW)	17.75 451	20.00 508	22.75 578	26.50 673	36.00 914	40.25 1022	50.00 1270	56.00 1422	- -	- -	- -	- -	- -	in mm
L2 (RTJ)	17.88 454	20.50 514	23.00 584	26.88 683	36.50 927	40.88 1038	50.88 1292	56.88 1445	- -	- -	- -	- -	- -	in mm
H (open)	24.88 631	29.00 736	35.00 890	41.50 1055	57.00 1450	63.38 1610	81.75 2075	89.75 2280	- -	- -	- -	- -	- -	in mm
Do	12 300	18 450	20 500	20 500	24 600	24 600	24 600	24 600	- -	- -	- -	- -	- -	in mm
wt(kg)	155 124	210 160	310 245	580 460	1600 1310	2450 2010	4570 3800	7150 6000	- -	- -	- -	- -	- -	RF BW

Applicable Standards:

DESIGN & MANUFACTURE CONFORM WITH: API 6D/ISO 14313, ASME B16.34
 CONNECTION DIMENSION CONFORMS WITH: ASME B16.5 DIN EN 1092
 FIRE RESISTANCE DESIGN CONFORMS WITH: API 607/ISO 10497
 INSPECTION & TEST CONFORMS WITH: API 6D, ISO 5208, API 598
 MATERIAL CONFORMS WITH: ISO 15156

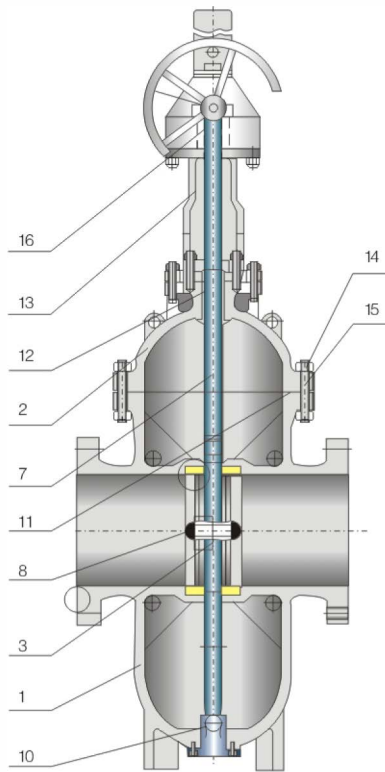

Single disk with pilot port structure

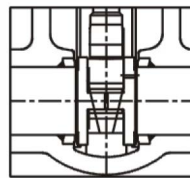

Double disk non-diversion hole structure

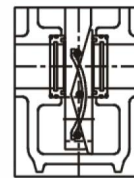

Double disk with diversion hole structure

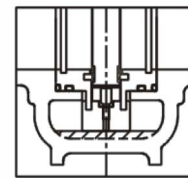

Single disk non-diversion hole structure

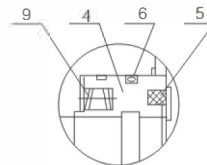

Soft sealing structure

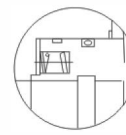

Hard sealing structure

Product Features

- 1、 Valve seat adopts the structure of O-ring seals and pretightening float valve seat, the soft sealing inlays fluoroplastic, it provides the function of double sealing: fluoroplastic to metal and metal to metal. And at the same time, the fluoroplastic can remove the dirt of the gate disk.
- 2、 Of the metal to metal sealing, there is a grease injection structure outside the valve, grease injects the sealing part through the seat, in this way achieves the aim of zero leakage.
- 3、 Through conduit gate valve always coincide with the sealing surface, whether the disc is full open-or full-closed; sealing surface to be protected from scouring by media directly, thereby extending the service life. In full-time, smooth channel for the direct and flow resistance coefficient is extremely small, no pressure loss, leading to Fig.

Materials of parts

Body	WCB/LCB/CF8M/CF8/CF3M/CF3/WC6/WC9/CD3MN
Bonnet	WCB/LCB/CF8M/CF8/CF3M/CF3/WC6/WC9/CD3MN
Disc	A105+ENP/LF2+ENP/F304/F316/F304L/F316L/F51
Seat	A105+ENP/LF2+ENP/F304/F316/F304L/F316L/F51
Stem	F6a/F304/F316/F304L/F316L/F51
Seal ring	PTFE/NYLON/PEEK/TEFLON
Sealing surface material	1~12 Trim material
O-ring	VITON/NBR
Bolt	B7M/B8M/L7M/B16M
Nut	2HM/8M/7M/4M
Spring	17-4PH/Inconel
Stem nut	C95200/D2/A536
Gasket	Flexible graphite+304/Flexible graphite+316
Packing	Flexible graphite/PTFE

Materials could be choosed according to customers' requirement & working condition.

Applicable Standards:

DESIGN & MANUFACTURE CONFORM WITH: API 6D/ISO 14313, ASME B16.34
 CONNECTION DIMENSION CONFORMS WITH: ASME B16.5 DIN EN 1092
 FIRE RESISTANCE DESIGN CONFORMS WITH: API 607/ISO 10497
 INSPECTION & TEST CONFORMS WITH: API 6D, ISO 5208, API 598
 MATERIAL CONFORMS WITH: ISO 15156

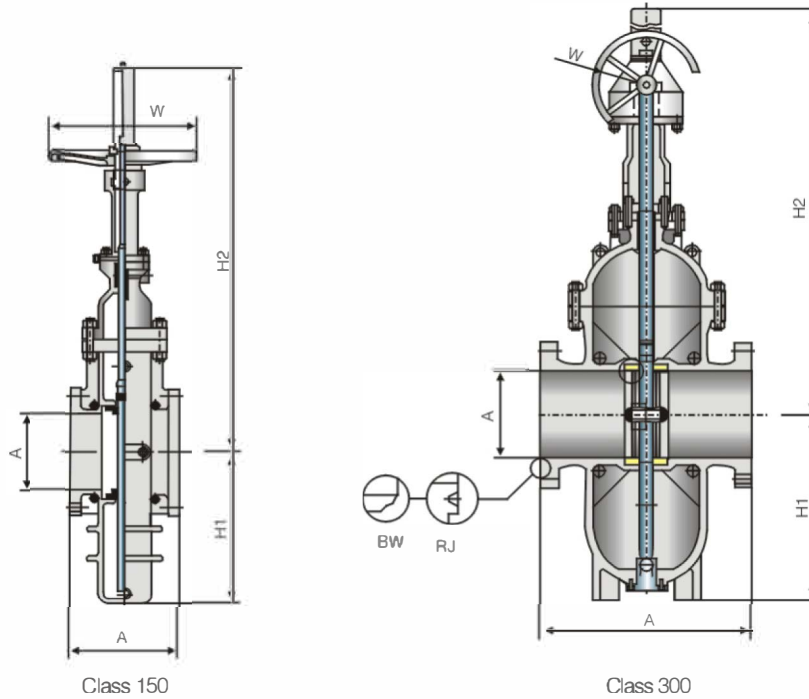

Dimensional datas

NPS inch	DN	A mm	B mm	H1 mm	H2 mm	W mm	WT kg	T N.m	NPS inch	DN	A mm	B mm	H1 mm	H2 mm	W mm	WT kg	T N.m
ANSI Class 150Lb																	
2	50	178	51	125	452	200	25	23	16	400	406	385	685	1854	560	630	572
3	80	203	76	175	605	250	43	50	18	450	432	436	790	2088	650	836	728
4	100	229	100	202	680	280	65	60	★20	500	457	487	880	2420	460	1190	910
6	150	267	150	282	890	300	95	78	★24	600	508	589	1050	2688	460	1580	1313
8	200	292	201	355	1128	350	146	143	★28	700	610	684	1192	3078	460	2400	2028
10	250	330	252	445	1296	400	245	211	★30	750	610	735	1268	3252	600	3200	2305
12	300	356	303	518	1483	450	343	289	★32	800	711	779	1355	3495	600	3700	2795
14	350	381	334	606	1668	500	480	403	★36	900	711	874	1515	3898	600	4600	3783

Dimensional datas

NPS inch	DN	A mm	B mm	H1 mm	H2 mm	W mm	WT kg	T N.m	NPS inch	DN	A mm	B mm	H1 mm	H2 mm	W mm	WT kg	T N.m
ANSI Class 300Lb																	
2	50	292	51	135	456	200	30	25	16	400	902	385	730	1884	650	1280	735
3	80	356	76	182	618	250	48	71	★18	450	978	436	802	2163	460	1665	988
4	100	406	100	216	713	280	78	95	★20	500	1054	487	935	2420	460	2168	1235
6	150	495	150	315	903	350	152	117	★24	600	1232	589	1103	2810	460	2980	1963
8	200	597	201	382	1133	400	240	185	★28	700	1397	684	1262	3203	460	4060	2990
10	250	673	252	480	1403	450	420	292	★30	750	1524	735	1342	3412	600	4980	3566
12	300	762	303	545	1582	500	525	366	★32	800	1651	779	1422	3646	600	5800	4121
14	350	826	334	645	1688	560	810	576	★36	900	1880	874	1513	4055	600	7790	5785

Note: ★ Worm-gear actuator

Applicable Standards:

DESIGN & MANUFACTURE CONFORM WITH: API 6D/ISO 14313, ASME B16.34
 CONNECTION DIMENSION CONFORMS WITH: ASME B16.5 DIN EN 1092
 FIRE RESISTANCE DESIGN CONFORMS WITH: API 607/ISO 10497
 INSPECTION & TEST CONFORMS WITH: API 6D, ISO 5208, API 598
 MATERIAL CONFORMS WITH: ISO 15156

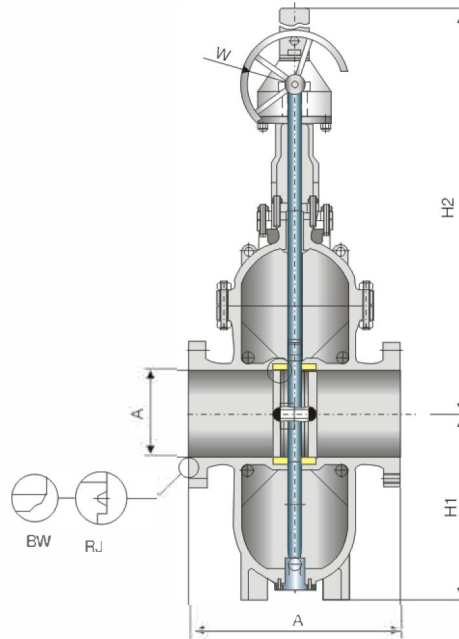

Dimensional datas

NPS inch	DN	A mm	B mm	H1 mm	H2 mm	W mm	WT kg	T N.m	NPS inch	DN	A mm	B mm	H1 mm	H2 mm	W mm	WT kg	T N.m
ANSI Class 600Lb																	
2	50	292	51	160	466	250	60	32	★ 14	350	889	334	654	1745	460	1680	1453
3	80	356	76	228	622	280	106	117	★ 16	400	991	385	740	1978	460	2230	2103
4	100	432	100	258	724	350	160	169	★ 18	450	1092	436	812	2268	600	2700	2808
6	150	559	150	332	913	450	395	234	★ 20	500	1194	487	1040	2509	600	3100	3653
8	200	660	201	411	1148	560	605	319	★ 24	600	1397	589	1160	2820	600	5100	4953
10	250	787	252	493	1412	600	960	737	★ 28	700	1549	684	1288	3233	1000	7050	6253
12	300	838	303	577	1596	650	1520	1274	★ 30	750	1651	735	1330	3442	1000	8200	7163

Dimensional datas

NPS inch	DN	A mm	B mm	H1 mm	H2 mm	W mm	WT kg	T N.m	NPS inch	DN	A mm	B mm	H1 mm	H2 mm	W mm	WT kg	T N.m
ANSI Class 900Lb																	
2	50	368	49	162	476	300	133	71	12	300	965	303	577	1600	460	1850	1296
3	80	381	74	230	638	350	198	150	14	350	1029	322	660	1755	460	2580	1482
4	100	457	100	262	730	400	260	181	16	400	1130	373	750	2028	600	3500	2139
6	150	610	150	336	920	560	565	413	18	450	1219	423	822	2288	600	4400	2919
8	200	737	201	415	1152	600	965	767	20	500	1321	471	1058	2525	600	5560	4486
★ 10	250	838	252	496	1418	460	1280	1021	24	600	1549	589	1176	2850	1000	7480	5195

Dimensional datas

NPS inch	DN	A mm	B mm	H1 mm	H2 mm	W mm	WT kg	T N.m	NPS inch	DN	A mm	B mm	H1 mm	H2 mm	W mm	WT kg	T N.m
ANSI Class 1500Lb																	
2	50	368	49	162	476	300	133	107	★ 6	150	705	144	338	930	460	830	618
3	80	470	74	230	638	400	235	225	★ 8	200	832	192	420	1160	460	1380	1151
4	100	546	100	270	745	500	398	272	★ 10	250	991	239	500	1428	460	2230	1532

Note: ★ Turbine drives