

## Design

The cast steel globe valves are designed and manufactured to provide maximum service life and dependability. All globe valve are full ported and meet the design requirements of American Petroleum Institute standard API600& 6D.BS EN 13709 and generally conform to American Society of Mechanical Engineers standard ASME B16.34. Valves are available in a complete range of body/bonnet materials and trims.

## Available Modifications

Trim changes  
End connection modifications  
Packing and gasket changes  
Operator mounting  
Handwheel extensions

## Ranger of Materials

Standard body/bonnet materials include nine grades of carbon, low alloy and stainless steel, for special applications they can be supplied in other grades of alloy and stainless steel, there's a full range of trim materials to match any service optional packing and gasket materials are available for a full range of service conditions.

Pressure equalizing  
By-pass  
Customer specified coatings  
Weld end bore changes  
Oxygen & chlorine cleaning & packaging

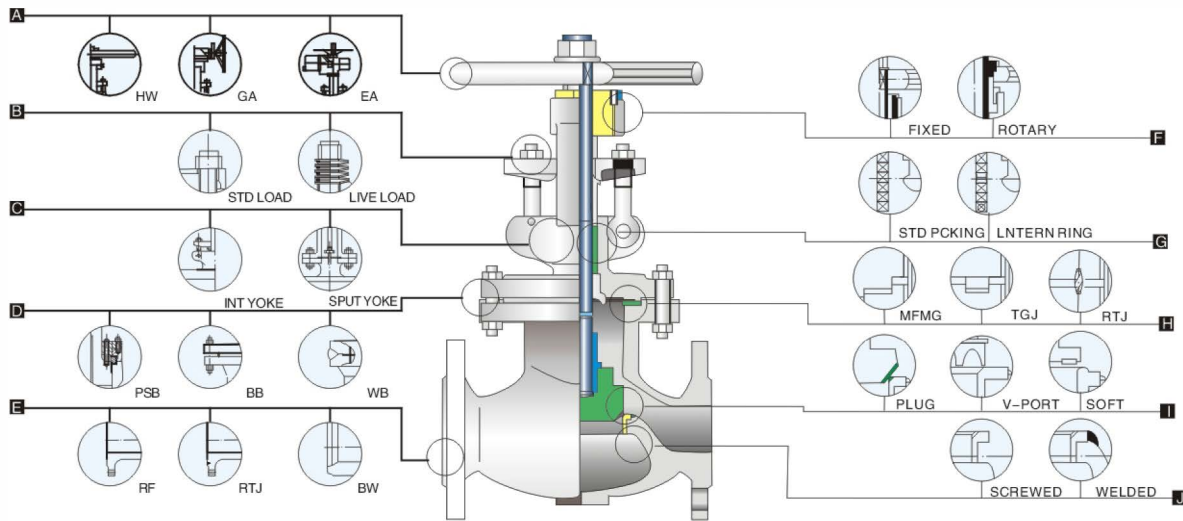

### **A** Operation

Large handwheels for easy operation. Also available with gearing, motor actuators, pneumatic or hydraulic actuators for more difficult services.

### **B** Live Load Packing

In services requiring frequent cycling or with high pressure/temperature variations, live loading extends the service life between maintenance periods packing gland adjustments. Belleville spring are employed to provide constant packing gland stress.

### **C** OS & Y

Outside screw and yoke. Cast steel globe valve yoke integral with bonnet for 10 & smaller.

### **D** BB

Bolted bonnet welding bonnet and pressure seal bonnet in services requiring frequent cycling or with high pressure/temperature variations.

### **E** End Connections

A choice of flanged, RTJ flanged or buttwelding end for piping flexibility.

### **F** Yoke sleeve

Furnished in aluminum bronze to reduce operating torque. Most size furnished with ball bearing yoke sleeves.

### **G** Lantern Ring And Double Packing Set

Lantern ring with leak-off fitting connection and double packing stack is optionally available for critical services.

### **H** Body-to-Bonnet Joint

A male and female joint or tongue and groove joint is used 150Lb to 600Lb valves, ring joint is used in the body to bonnet connection in 900Lb & higher rated valves.

### **I** Disc

Plug disc is stem guided on all size. Disc has a differential angle front the seat to provide a line contact for maximum sealing. The bottom of v-port disc is guided by the body seat ring for maximum disc stability in throttling applications, the soft teflon ring is excellent for lower temperature service where tight shut off required.

### **J** Seat Rings

Separate heavy duty, full ported rings for easy maintenance. Screwed or welded connection into body.

## Applicable Standards:

- STEEL GLOBE VALVES BS EN 13709/API 600
- STEEL VALVES, ASME B16.34
- FACE TO FACE, ASME B16.10
- END FLANGES, ASME B16.5
- BUTTWELDING ENDS, ASME B16.25
- INSPECTION AND TEST, API 598

## Design descriptions:

- STRAIGHT PATTERN BODY DESIGN
- OS&Y, OUTSIDE SCREW AND YOKE
- BB, BOLTED BONNET
- YOKE INTEGRAL WITH BONNET
- RISING STEM AND HANDWHEEL
- LOOSE DISC, CHOICE OF PLUG OR BALL
- RENEWABLE SEAT RING
- IMPACT HANDWHEEL FOR 10" & ABOVE
- HORIZONTAL SERVICE
- FLANGED OR BUTTWELDING ENDS
- AVAILABLE WITH BG OPERATOR

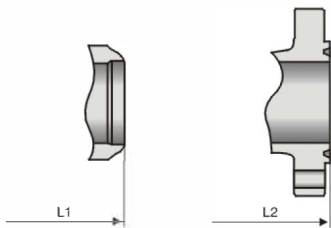
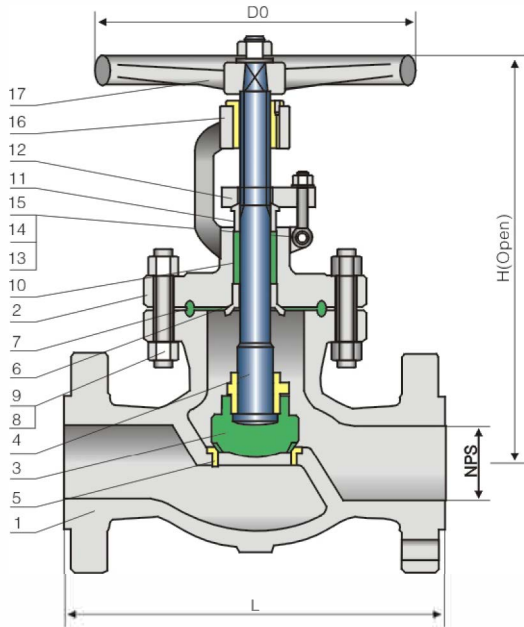

## Materials of parts

No	Part Name	ASTM Materials		
		Carbon Steel	1 1/4Cr-1/2Mo	Carbon Steel
1	Body	A216-WCB	A217-WC6	A352-LCB
2	Bonnet	A216-WCB	A217-WC6	A352-LCB
3	Disc	A105+CR13	A182-F11+HF	A350-LF2+CR13
4	Stem	A182-F6a	CR-MO-V	A182-F6a
5	Seat Ring	A105+HF	A182-F11+HF	A350-LF2+HF
6	Stem Backseat	A276-420	A276-304	A276-420
7	Bonnet Gasket	Steel Ring	304SS Ring	Steel Ring
8	Bonnet Stud	A193-B7	A193-B16	A320-L7
9	Bonnet Stud Nut	A194-2H	A194-7	A194-4
10	Packing	Graphite		
11	Gland	A276-420	A276-304	A276-420
12	Gland Flange	A216-WCB	A217-WC6	A352-LCB
13	Eyebolt Pin	Carbon Steel	A276-420	Carbon Steel
14	Eyebolt	Carbon Steel	A193-B7	Carbon Steel
15	Eyebolt Nut	Carbon Steel	A194-2H	Carbon Steel
16	Yokesleeve	Aluminum-Bronze <sup>1)</sup>		
17	Handwheel	Malleable Iron		

Note: 1) Ductile Ni-resist optional

2) Disc and seat ring may either be solid facing material or a base material equal to or better than the body/bonnet material with facing as shown.

## Dimensional datas

NPS	DN	L/L1 (RF/BW)		L2 (RTJ)		H (open)		D0		WT(kg)		L/L1 (RF/BW)		L2 (RTJ)		H (open)		D0		WT(kg)	
ANSI Class 150Lb												ANSI Class 300Lb									
2	50	8.00	203	8.00	203	15.00	380	7	180	18	14	10.50	267	11.12	282	16.75	425	8	200	25	20
2 1/2	65	8.50	216	8.50	216	21.00	535	10	240	30	22	11.50	292	12.12	308	19.00	485	10	240	32	22
3	80	9.50	241	9.50	241	17.50	445	11	280	41	33	12.50	318	13.12	333	19.88	505	11	280	38	27
4	100	11.50	292	11.50	292	20.25	515	11	280	64	43	14.00	356	14.62	371	22.50	570	13	320	56	41
6	150	16.00	406	16.00	406	22.00	560	13	320	86	72	17.50	444	18.12	460	25.25	640	16	400	96	75
8	200	19.50	495	19.50	495	24.25	615	13	320	110	88	22.00	559	22.62	575	33.25	845	18	450	150	117
10	250	24.50	622	24.50	622	32.00	815	16	400	280	245	24.50	622	25.12	638	35.50	900	20	500	360	310
12	300	27.50	698	27.50	698	35.88	910	18	450	380	345	28.00	711	28.62	727	38.62	980	24	600	550	492
14	350	31.00	787	31.00	787	48.38	1230	20	500	510	450	-	-	-	-	-	-	-	-	-	-
16	400	36.00	914	36.00	914	57.00	1450	24	600	740	665	-	-	-	-	-	-	-	-	-	-
in	mm	in	mm	in	mm	in	mm	in	mm	RF	BW	in	mm	in	mm	in	mm	in	mm	RF/RTJ	BW

## Applicable Standards:

- STEEL GLOBE VALVES BS EN 13709/API 600
- STEEL VALVES, ASME B16.34
- FACE TO FACE, ASME B16.10
- END FLANGES, ASME B16.5
- BUTTWELDING ENDS, ASME B16.25
- INSPECTION AND TEST, API 598

## Design descriptions:

- STRAIGHT PATTERN BODY DESIGN
- OS&Y, OUTSIDE SCREW AND YOKE
- BB, BOLTED BONNET
- YOKE INTEGRAL WITH BONNET
- RISING STEM AND HANDWHEEL
- LOOSE DISC, CHOICE OF PLUG OR BALL
- RENEWABLE SEAT RING
- IMPACT HANDWHEEL FOR 10" & ABOVE
- HORIZONTAL SERVICE
- FLANGED OR BUTTWELDING ENDS
- AVAILABLE WITH BG OPERATOR

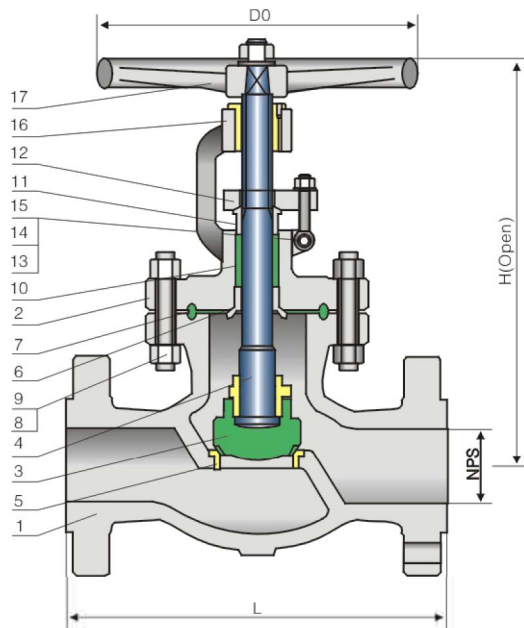

## Materials of parts

No	Part Name	ASTM Materials		
		Carbon Steel	1 1/4Cr-1/2Mo	Carbon Steel
1	Body	A216-WCB	A217-WC6	A352-LCB
2	Bonnet	A216-WCB	A217-WC6	A352-LCB
3	Disc	A105+CR13	A182-F11+HF	A350-LF2+CR13
4	Stem	A182-F6a	CR-MO-V	A182-F6a
5	Seat Ring	A105+HF	A182-F11+HF	A350-LF2+HF
6	Stem Backseat	A276-420	A276-304	A276-420
7	Bonnet Gasket	Steel Ring	304SS Ring	Steel Ring
8	Bonnet Stud	A193-B7	A193-B16	A320-L7
9	Bonnet Stud Nut	A194-2H	A194-7	A194-4
10	Packing	Graphite		
11	Gland	A276-420	A276-304	A276-420
12	Gland Flange	A216-WCB	A217-WC6	A352-LCB
13	Eyebolt Pin	Carbon Steel	A276-420	Carbon Steel
14	Eyebolt	Carbon Steel	A193-B7	Carbon Steel
15	Eyebolt Nut	Carbon Steel	A194-2H	Carbon Steel
16	Yokesleeve		Aluminum-Bronze <sup>1)</sup>	
17	Handwheel		Malleable Iron	

Note: 1) Ductile Ni-resist optional

2) Disc and seat ring may either be solid facing material or a base material equal to or better than the body/bonnet material with facing as shown.

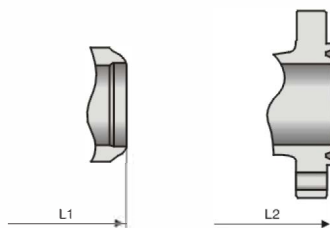

## Dimensional datas

NPS	DN	L/L1 (RF/BW)		L2 (RTJ)		H (open)		D0		WT(kg)		L/L1 (RF/BW)		L2 (RTJ)		H (open)		D0		WT(kg)	
ANSI Class600Lb												ANSI Class900Lb									
2	50	11.50	292	11.62	295	17.50	445	10	240	35	27	14.50	368	14.62	371	22.00	560	11	280	57	41
2 1/2	65	13.00	330	13.12	333	19.75	502	11	280	50	34	16.50	419	16.62	422	23.25	590	13	320	82	53
3	80	14.00	356	14.12	359	21.00	533	13	320	60	42	15.00	381	15.12	384	25.25	640	16	400	91	58
4	100	17.00	432	17.12	435	24.50	622	16	400	110	84	18.00	457	18.12	460	31.88	810	18	450	168	117
6	150	22.00	559	22.12	562	29.50	750	18	450	230	192	24.00	610	24.12	613	41.38	1050	20	500	365	238
8	200	26.00	660	26.12	663	36.50	927	20	500	410	350	29.00	737	29.12	740	53.50	1360	24	600	665	538
10	250	31.00	787	31.12	790	44.88	1140	24	600	770	680	33.00	838	33.12	841	61.88	1570	24	600	1250	1060
12	300	33.00	838	33.12	841	53.12	1350	24	600	1140	1030	-	-	-	-	-	-	-	-	-	-
in	mm	in	mm	in	mm	in	mm	in	mm	RF/RTJ	BW	in	mm	in	mm	in	mm	in	mm	RF/RTJ	BW

## Applicable Standards:

- STEEL GLOBE VALVES BS EN 13709/API 600
- STEEL VALVES, ASME B16.34
- FACE TO FACE, ASME B16.10
- END FLANGES, ASME B16.5
- BUTTWELDING ENDS, ASME B16.25
- INSPECTION AND TEST, API 598

## Design descriptions:

- STRAIGHT PATTERN BODY DESIGN
- OS&Y, OUTSIDE SCREW AND YOKE
- BB, BOLTED BONNET
- YOKE INTEGRAL WITH BONNET
- RISING STEM AND HANDWHEEL
- LOOSE DISC, CHOICE OF PLUG OR BALL
- RENEWABLE SEAT RING
- IMPACT HANDWHEEL FOR 10" & ABOVE
- HORIZONTAL SERVICE
- FLANGED OR BUTTWELDING ENDS
- AVAILABLE WITH BG OPERATOR

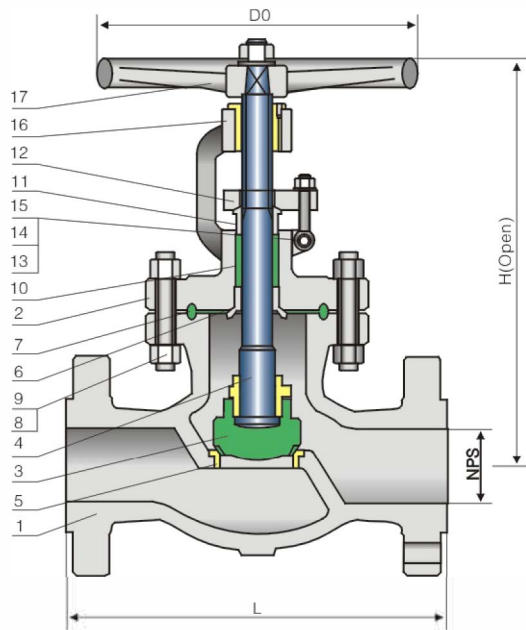

## Materials of parts

No	Part Name	ASTM Materials		
		Carbon Steel	1 1/4Cr-1/2Mo	Carbon Steel
1	Body	A216-WCB	A217-WC6	A352-LCB
2	Bonnet	A216-WCB	A217-WC6	A352-LCB
3	Disc	A105+CR13	A182-F11+HF	A350-LF2+CR13
4	Stem	A182-F6a	CR-MO-V	A182-F6a
5	Seat Ring	A105+HF	A182-F11+HF	A350-LF2+HF
6	Stem Backseat	A276-420	A276-304	A276-420
7	Bonnet Gasket	Steel Ring	304SS Ring	Steel Ring
8	Bonnet Stud	A193-B7	A193-B16	A320-L7
9	Bonnet Stud Nut	A194-2H	A194-7	A194-4
10	Packing	Graphite		
11	Gland	A276-420	A276-304	A276-420
12	Gland Flange	A216-WCB	A217-WC6	A352-LCB
13	Eyebolt Pin	Carbon Steel	A276-420	Carbon Steel
14	Eyebolt	Carbon Steel	A193-B7	Carbon Steel
15	Eyebolt Nut	Carbon Steel	A194-2H	Carbon Steel
16	Yokesleeve		Aluminum-Bronze <sup>1)</sup>	
17	Handwheel		Malleable Iron	

Note: 1) Ductile Ni-resist optional

2) Disc and seat ring may either be solid facing material or a base material equal to or better than the body/bonnet material with facing as shown.

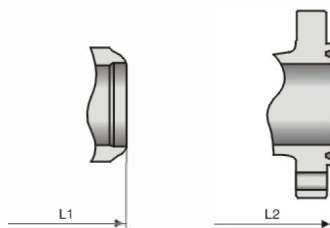

## Dimensional datas

NPS	DN	L/L1 (RF/BW)	L2 (RTJ)	H (open)	D0	WT(kg)	L/L1 (RF/BW)	L2 (RTJ)	H (open)	D0	WT(kg)
<b>ANSI Class1500Lb</b>						<b>ANSI Class2500Lb</b>					
2	50	14.50	368	14.62	371	22.00	560	13	320	68	57
2 1/2	65	16.50	419	16.62	422	23.25	590	16	400	97	81
3	80	18.50	470	18.62	473	29.50	750	18	450	116	95
4	100	21.50	546	21.62	549	36.00	915	20	500	184	148
6	150	27.75	705	28.00	711	48.62	1235	24	600	347	267
8	200	32.75	832	33.12	841	65.00	1650	28	700	635	472
in	mm	in	mm	in	mm	in	mm	in	mm	in	mm
		in	mm	in	mm	in	mm	in	mm	in	mm